



PUT WASTE HEAT TO USE

with our gas-heated steam humidifier,
Condair **GS**



Humidification, dehumidification
and evaporative cooling

 **condair**

Cost-effective and eco-friendly steam production with natural gas as the primary energy source



Natural gas-fueled steam humidification

For efficient operation, natural gas as the primary source of energy can be used as a cost-efficient alternative to conventional steam humidification with electricity.

Efficient surface burner

Stainless steel tank construction

Heat exchangers

Innovative heat exchanger construction made of robust stainless steel tubes without welding seams.

Heat exchange chamber

Largest possible access area for maintenance work.

Base frame for floor installation

The base frame is designed to ensure stable and easy installation of the equipment and the perfect height for carrying out maintenance and assembly work.

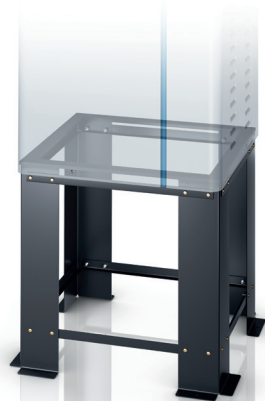

DVGW-certified exhaust installation

With Condair GS, exhaust gas can be used for direct heat recovery in the HVAC unit. This patented and DVGW-certified technology eliminates the need for a chimney, so both the initial investment and operating costs are exceptionally affordable.

Touch Controller for precise control

The Condair GS is available in seven different output variants, allowing continuous adjustment. The microprocessor-controlled device interface can be operated with all commonly-used control signals.

Perfect integration into Building Management Systems



High energy efficiency with optional condensing heat exchanger

With an auxiliary heat exchanger at the fresh water inlet (GS CS version), heat can be transferred from the exhaust gas to the humidification water with high thermal efficiency.



Exhaust gas discharge and heat recovery through the HVAC system

Using HVAC exhaust air to discharge exhaust gas offers great advantages, especially for renovations where there is no chimney. Furthermore, it also makes installation much easier in new construction projects.

A range of power levels let you select the right unit for your needs, for use in a wide area of applications. In addition, the heat output achieved in the HVAC unit increases with the volume of steam.

Exhaust gas heat is used regeneratively through heat recovery in the HVAC unit, with no negative impact on the quality of exhaust air. The energy in the exhaust gas becomes available for free, and the resulting savings can be applied to your ventilation heating needs.

No chimney required



Recovery of exhaust gas heat



DVGW certified



Efficient condensing heat exchanger with conventional exhaust gas discharge (option)

If there is no possibility of heat recovery through the HVAC system, energy efficiency can be increased by adding a condensing heat exchanger to the humidifier itself.

humidification water with high thermal efficiency.

In the Condair GS CS version, a condensing heat exchanger at the fresh water inlet transfers heat from the exhaust gas to the

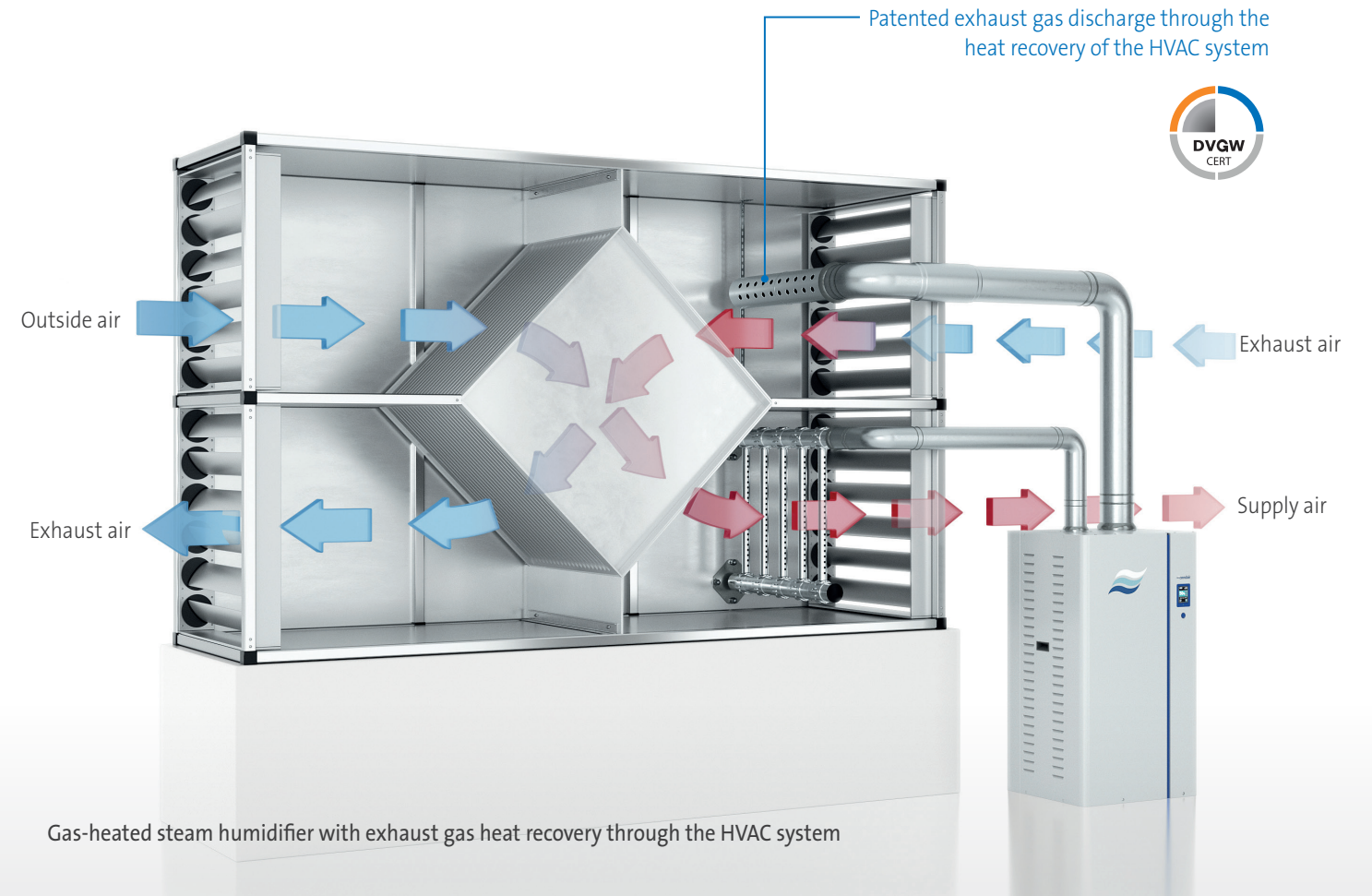
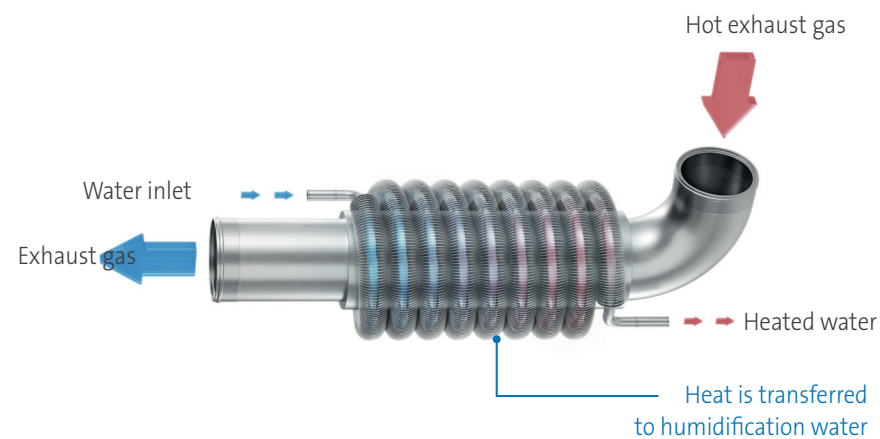

Potential savings through ventilation heat consumption, including condensation heat
Heat recovery [kW]

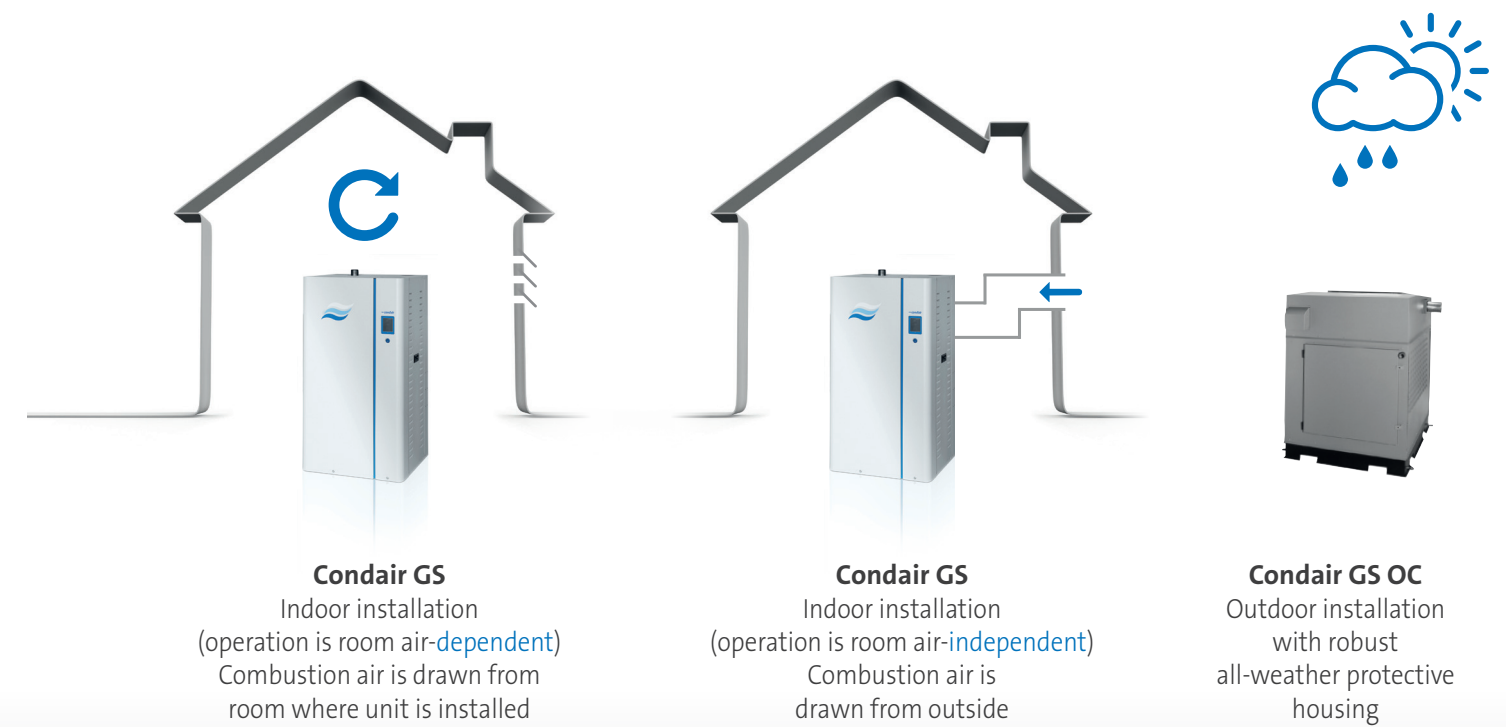
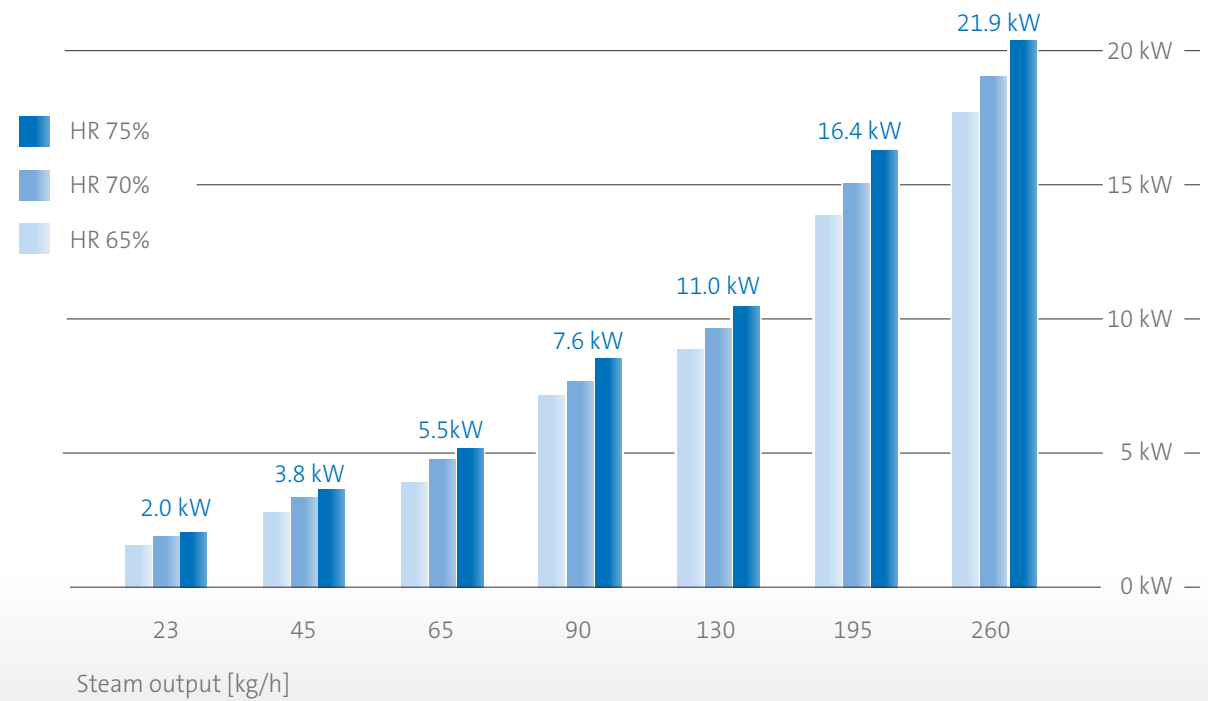

Efficient technology pays off!

Steam output	Exhaust gas heat	HR 65%	HR 70%	HR 75%
23 kg/h	2,6 kW	~ 1,7 kW (1)	~ 1,8 kW (1)	~ 2,0 kW (1)
45 kg/h	5,1 kW	~ 3,3 kW (2)	~ 3,6 kW (2)	~ 3,8 kW (2)
65 kg/h	7,3 kW	~ 4,7 kW (2)	~ 5,1 kW (3)	~ 5,5 kW (3)
90 kg/h	10,1 kW	~ 6,6 kW (3)	~ 7,1 kW (4)	~ 7,6 kW (4)
130 kg/h	14,6 kW	~ 9,5 kW (5)	~ 10,2 kW (5)	~ 11,0 kW (6)
195 kg/h	21,9 kW	~ 14,2 kW (7)	~ 15,3 kW (8)	~ 16,4 kW (9)
260 kg/h	29,2 kW	~ 19,0 kW (10)	~ 20,4 kW (11)	~ 21,9 kW (11)

Total usable exhaust gas heat output is the result of sensible heat, achieved through the high exhaust gas temperature, and latent heat, in the form of steam. The values in parentheses represent sensible heat gain without condensation heat.

Flexible application

Different system situations require customized solutions. With a range of Condair GS variants to choose from, you can select a unit that precisely matches your planning requirements and the design of your HVAC system. Existing limitations

are overcome through the exhaust gas discharge system, and highly efficient steam humidification is made available for a wide range of applications.

Standard version

- Stainless steel steam cylinder
- Internal PI humidity controller
- Remote signaling of operational readiness / operating mode / maintenance / faults
- Analog signal for current steam production
- Control panel with LCD display
- Self-diagnosis system

Accessories

- Steam distributor for duct [1]
- Steam distribution hose [2]
- Condensate hose [3]
- DVGW-certified exhaust gas installation [4]
- Exhaust gas distributor [5]
- Base frame for floor installation

Options

- CS version with high-efficiency auxiliary heat exchanger
- OptiSorp multiple steam distribution system
- Humidity sensor for duct/room installation
- Duct/room hygrostat
- Pressure relief valve set (up to 10,000 Pa pressure relief)
- Connection to BMS with e-links (e.g. for Modbus, BACnet/IP and LonWorks)

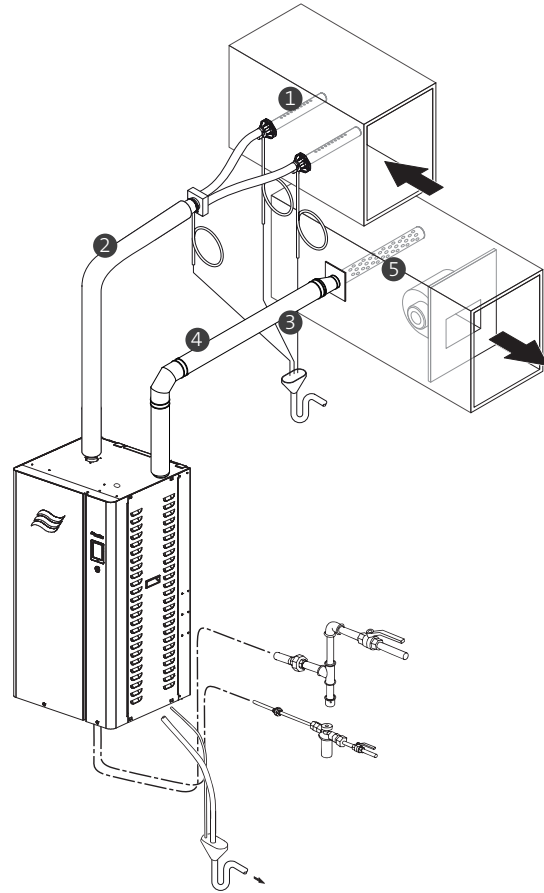

Technical Data

GS and GS CS models		GS 23	GS 45	GS 65	GS 90	GS 130	GS 195	GS 260
Steam output (nominal capacity)	kW/h	21	41	62	82	123	185	246
Minimum exhaust air flow*	m ³ /h	1,025	2,050	3,075	4,100	6,150	9,225	12,300
Exhaust air — negative pressure*	Pa	-300 – -1,200 and -400 – -1,500 (other ranges available by request)						
Control voltage	V/PH/Hz	230 / 1 / 50–60						
Max/Min input (GS models)	kW	20.5 / 4.1	41 / 8.2	61.5 / 12.3	82 / 8.2	123 / 12.3	184.5 / 12.3	246 / 12.3
Max/Min input (GS CS models)	kW	18.2 / 3.6	36.4 / 7.3	54.5 / 10.9	72.7 / 7.3	109 / 10.9	163.5 / 10.9	218 / 10.9
Width/height	mm	600 x 1,110		710 x 1,410	960 x 1,410		1,590 x 1,410	
Depth	mm	540	540	710	710	710	710	710

GS-OC model (outdoor installation)		GS OC 40	GS OC 80	GS OC 120	GS OC 160	GS OC 200	GS OC 240
Steam output	kW/h	40	80	120	160	200	240
Width/height	mm	1,262 / 1,380					
Depth	mm	545	708	1,104	1,104	1,500	1,500
Compliance		DVGW, CE, VDE					

* in conjunction with exhaust gas utilization